

Unidirectional Mechanical Amplification as a Design Principle for an Active Microphone

Tobias Reichenbach and A. J. Hudspeth

Howard Hughes Medical Institute and Laboratory of Sensory Neuroscience, The Rockefeller University,
1230 York Avenue, New York, New York 10065-6399, USA

(Received 25 December 2010; revised manuscript received 2 March 2011; published 14 April 2011)

Amplification underlies the operation of many biological and engineering systems. Simple electrical, optical, and mechanical amplifiers are reciprocal: the backward coupling of the output to the input equals the forward coupling of the input to the output. Unidirectional amplifiers that occur often in electrical and optical systems are special nonreciprocal devices in which the output does not couple back to the input even though the forward coupling persists. Here we propose a scheme for unidirectional mechanical amplification that we utilize to construct an active microphone. We show that amplification improves the microphone's threshold for detecting weak signals and that unidirectionality prevents distortion.

DOI: 10.1103/PhysRevLett.106.158701

PACS numbers: 43.80.+p, 07.07.Df, 07.64.+z, 43.58.+z

Maxwell's reciprocity theorem in mechanics states that a force applied at a point A , such as an amplifier's input, produces a displacement at a point B , say the amplifier's output, that equals the displacement at A caused by an equal force at B [1,2] [Fig. 1(a)]. Similar reciprocal relations govern electrical circuits [3] and optics [1]. They represent a potential problem in the design of amplifiers, for an ideal amplifier should operate unidirectionally: although the signal at the input must control the output, to avoid feedback and distortion the output should not couple back to the input [Fig. 1(b)]. Reciprocity can be violated in electrical circuits through the use of semiconductors and in optical systems through Faraday rotation [1,4]. Amplifiers in electrical engineering and microwave devices therefore employ these effects to achieve unidirectionality [4,5].

Mechanical amplification can enhance the detection of a weak signal by raising its amplitude above the noise level. Biology employs this strategy in hearing, for mechanosensitive hair cells in the vertebrate inner ear actively amplify weak sounds and thereby greatly lower the threshold of hearing [6,7]. In contrast, microphones—the ear's technological analogues—are passive devices that do not employ mechanical amplification but rely on subsequent electronic signal processing. One difficulty in implementing mechanical amplification in microphones is the reciprocity described above, which leads to undesired feedback and hence highlights the need for a mechanism of unidirectional mechanical amplification. We have recently described how such a mechanism may operate in the mammalian inner ear, where hair cells provide piezoelectric coupling [8] between the input and output that can foster unidirectionality [9,10]. Here we show that a similar strategy can be used to implement unidirectional mechanical amplification in a microphone.

A dynamic microphone functions by the same principle as a dynamic speaker [11]: a diaphragm is attached to a coil that moves in a magnetic field [Fig. 1(c)]. Sound vibrates

the diaphragm and thereby causes oscillations of the coil that electromagnetically induce a voltage. Such a system serves as a speaker when an oscillatory electrical signal is applied to the coil; the consequent Lorentz force vibrates the coil and hence the diaphragm, emitting sound. The system's dual function as microphone and speaker therefore results from two potential forces. An external sound force F_{ext} acts on the diaphragm, representing the microphone's input, and the internal Lorentz force $F_{\text{int}} = IIB$

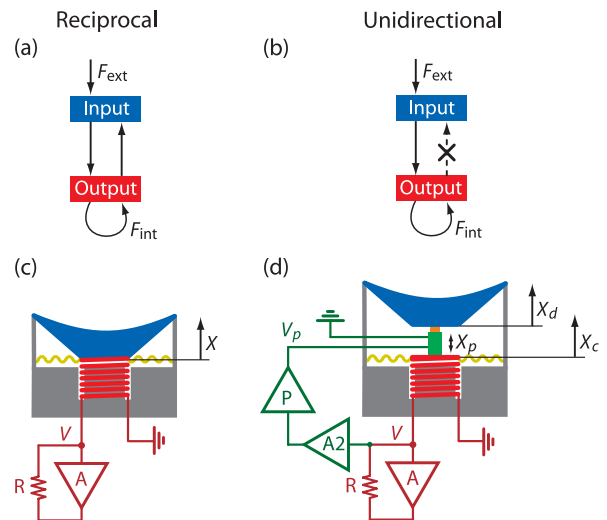

FIG. 1 (color). Amplifier and microphone designs. (a), (b) Schematic diagrams of reciprocal and unidirectional amplifiers. (c) In a dynamic microphone the spider (yellow) and diaphragm (blue) hold the voice coil (red) in a magnetic field. The coil's displacement can be amplified through amplifying the coil voltage V (amplifier A) and feeding it back into the coil through a resistance R . (d) Unidirectionality results from a piezoelectric element (green) in series with an elastic element (orange) placed between the coil and diaphragm. The piezoelectric element's length change X_p is controlled by a voltage V_p that results from the coil voltage V and that is adjusted through an amplifier $A2$ and a phase shifter P .

acts on the coil, corresponding to the output. Here I denotes the current in the coil, l the coil's length, and B the magnetic field. To linear order the diaphragm's displacement X then obeys

$$m\partial_t^2 X + \lambda\partial_t X + KX = F_{\text{int}} + F_{\text{ext}}, \quad (1)$$

in which m , λ , and K denote, respectively, the mass, damping coefficient, and stiffness of the coil together with the diaphragm and the entrained air. The voltage V induced by coil motion is

$$V = Bl\partial_t X. \quad (2)$$

Because of the system's dual function as both speaker and microphone it can readily be converted into a mechanically active microphone [Fig. 1(c)]. Indeed, positive feedback of the electrical signal in the coil can employ the internal Lorentz force to increase the coil's displacement resulting from an external sound force. To this end we have constructed a circuit in which the electrical signal in the coil is amplified and fed back into the coil through a resistance R [Fig. 1(c)]. The electrical amplification is unidirectional with an adjustable gain G achieved through an operational amplifier in the noninverting feedback configuration (supplemental material [12]). The amplifier's output voltage V_A in response to the input V is then $V_A = GV$ and fulfills $V_A - V = IR$; these relations may be employed to express the voltage V in terms of the current I :

$$V = \left(\frac{R}{G-1} \right) I. \quad (3)$$

To analyze Eqs. (1)–(3), we consider a pure tone of frequency f that produces an oscillatory external force $F_{\text{ext}} = \tilde{F}_{\text{ext}} e^{i\omega t} + \text{c.c.}$ in which the tilde denotes the Fourier component, $\omega = 2\pi f$ and “c.c.” denotes the complex conjugate. Because the equations are linear, the resulting displacement X , voltage V , and current I oscillate at the same frequency f : $X = \tilde{X} e^{i\omega t} + \text{c.c.}$, $V = \tilde{V} e^{i\omega t} + \text{c.c.}$, and $I = \tilde{I} e^{i\omega t} + \text{c.c.}$ The amplitudes follow as

$$\tilde{X} = \frac{1}{i\omega Z} \tilde{F}_{\text{ext}}, \quad \tilde{V} = \frac{Bl}{Z} \tilde{F}_{\text{ext}}, \quad \tilde{I} = \frac{(G-1)Bl}{RZ} \tilde{F}_{\text{ext}} \quad (4)$$

with the impedance

$$Z = i(m\omega - K/\omega) + \lambda - l^2 B^2 (G-1)/R. \quad (5)$$

Equation (5) defines a resonant frequency $\omega_0 = 2\pi f_0 = \sqrt{K/m}$ at which the imaginary part of the impedance vanishes. The real part results from the damping λ counteracted by the positive feedback. At a critical value of the gain $G_c = 1 + \lambda R/(l^2 B^2)$, the real part of the impedance vanishes; this value therefore defines a transition from damped to undamped oscillation [13,14]. Nonlinearities control the system's behavior at this bifurcation and yield

a transition from damped to stable limit-cycle oscillations consistent with a supercritical Hopf bifurcation (supplemental material [12]).

Operation at the Hopf bifurcation enhances the detection of sounds at the resonant frequency [5,15–17]. The active microphone's response is sharply tuned to the resonant frequency f_0 (supplemental material [12]) at which the linear part of the response vanishes [Eq. (5)] and the response becomes nonlinear. In our active microphone the response follows a power-law relation to stimulus amplitude with an exponent of about 0.5 [Fig. 2(b), supplemental material [12]]. Faint signals cause a significantly larger response than in the passive microphone. Amplification acts only on the noise component at the resonant frequency and not on the remaining noise spectrum and thus improves the signal-to-noise ratio and lowers the threshold for signal detection at the resonance [Figs. 2(a) and 2(b)]. Because an active microphone constructed in this way detects only a small band of frequencies near its resonance, an ensemble of such systems tuned to different resonant frequencies is required to cover a broader frequency range. Such an array of active oscillators indeed underlies hearing in the vertebrate inner ear [6,7].

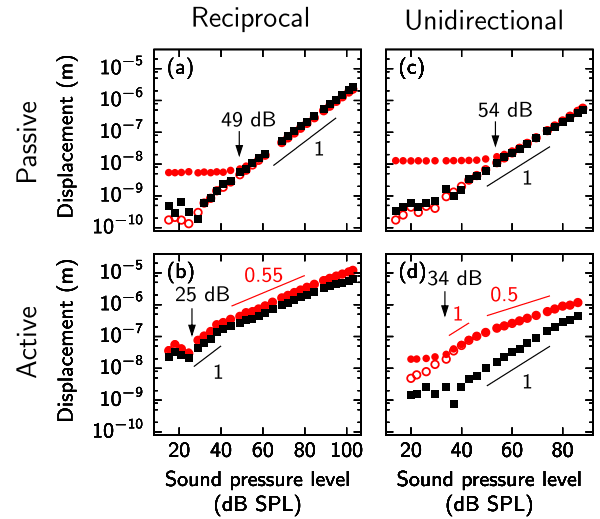

FIG. 2 (color online). Linear and nonlinear responses. The diaphragm's displacement (black squares) and the coil's displacement (red or grey circles) are presented as functions of the sound-pressure level for the reciprocal passive (a), the reciprocal active (b), the unidirectional passive (c), and the unidirectional active microphone (d) stimulated at the resonant frequencies of their active versions. The diaphragm's displacement is obtained from interferometric measurements for which we report the Fourier component. The coil's displacement is inferred from the coil's voltage; we display the Fourier component (red or grey open circles) as well as the root-mean-square value multiplied by $\sqrt{2}$ (red or grey full circles). Arrows indicate the detection thresholds at which the response enters the noise floor.

The active microphone described above operates reciprocally: the motion of the diaphragm, representing the input, is amplified by the coil's vibration, which corresponds to the output. Unidirectionality can be achieved by placing a piezoelectric element, controlled by the coil's electrical signal, between the diaphragm and coil [Fig. 1(d)]. The element's length change \tilde{X}_p is then proportional to the coil displacement \tilde{X}_c : $\tilde{X}_p = -\alpha\tilde{X}_c$ with a complex coefficient α determined by the electrical circuit. Because the external sound force acts on the diaphragm and the internal Lorentz force on the coil, the diaphragm's displacement \tilde{X}_d and the coil's displacement \tilde{X}_c follow from

$$i\omega A \begin{pmatrix} \tilde{X}_d \\ \tilde{X}_c \end{pmatrix} = \begin{pmatrix} \tilde{F}_{\text{ext}} \\ \tilde{F}_{\text{int}} \end{pmatrix} \quad (6)$$

with the matrix

$$A = \begin{pmatrix} Z_d + Z & -(1 + \alpha)Z \\ -Z & Z_c + (1 + \alpha)Z \end{pmatrix}. \quad (7)$$

Here Z_d denotes the impedance of the diaphragm, Z_c the impedance of the coil, and Z the impedance of a coupling element positioned between the piezoelectric element and the diaphragm [Fig. 1(d)].

The piezoelectrical coupling breaks reciprocity: when $\alpha \neq 0$, the coupling of the coil to the diaphragm, given by the matrix element A_{12} , differs from the coupling of the diaphragm to the coil, represented by A_{21} . At a critical value $\alpha_* = -1$ the coupling becomes unidirectional: the matrix element A_{12} vanishes and with it the coupling from the coil to the diaphragm, whereas A_{21} and thus the coupling from the diaphragm to the coil remains nonzero. Setting the coefficient α to its critical value α_* requires adjustment of both its amplitude and phase, which can be achieved through amplifying and subsequently phase-shifting the coil voltage [Fig. 1(d) and supplemental material [12]]. At the critical value α_* the displacements are

$$\tilde{X}_d = \frac{1}{i\omega(Z_d + Z)} \tilde{F}_{\text{ext}}, \quad (8)$$

$$\tilde{X}_c = \frac{Z}{i\omega Z_c(Z_d + Z)} \tilde{F}_{\text{ext}} + \frac{1}{i\omega Z_c} \tilde{F}_{\text{int}}. \quad (9)$$

Unidirectional coupling is manifest in these equations because the coil is displaced both by the external sound force and by the internal Lorentz force [Eq. (9)], whereas only the sound force acts on the diaphragm [Eq. (8)].

Because amplification in the unidirectional active microphone acts through the internal Lorentz force on the coil but not on the diaphragm, the coil's displacement exhibits a Hopf bifurcation at a critical gain whereas the motion of the diaphragm does not (supplemental material [12]). The system's response at the Hopf bifurcation reflects this difference: the coil's displacement and voltage exhibit nonlinear behavior because their linear responses vanish at

the bifurcation [Fig. 2(d)]. The diaphragm's displacement, however, shows a linear response for it does not encounter the amplification.

Amplification in the unidirectional active microphone lowers the threshold for detecting signals at the resonant frequency. Indeed, a passive unidirectional microphone that omits amplification through elimination of the active microphone's positive-feedback circuit exhibits a considerably higher threshold [Figs. 2(c) and 2(d)]. Because the piezoelectrical coupling introduces additional noise, the signal-detection thresholds in the passive and active unidirectional microphones are slightly increased compared to their reciprocal analogues (Fig. 2).

What is the benefit of unidirectionality in an active microphone? Amplification of the diaphragm requires energy that is spared with unidirectional coupling. The critical gain G_c of the amplifier at which the Hopf bifurcation emerges is therefore lower in the unidirectional microphone than in the reciprocal one (supplemental material [12]).

Another important advantage is prevention of distortion. The nonlinear response of an active microphone near its Hopf bifurcation causes the formation of distortion products [18]: when stimulated at two frequencies f_1 and f_2 the microphone also reports linear combinations of these frequencies such as $2f_1 - f_2$ and $2f_2 - f_1$. A strong response results if one distortion product coincides with the microphone's resonant frequency f_0 [Fig. 3(a)]. When amplification is reciprocal this distortion product is emitted from the active microphone because the coil transmits it to the diaphragm and a sound results [Figs. 3(a)–3(c)]. Unidirectional amplification, in contrast, prevents the emission of such a distortion product. Although the distortion product appears in the coil's voltage and displacement owing to the coil's operation near a Hopf bifurcation, the distortion product is not transmitted to the diaphragm and is therefore not emitted as sound [Figs. 3(d)–3(f)].

An ensemble of distortion products results when amplification is reciprocal. The number and frequency of distortion products to which an active microphone responds are determined by the form of the nonlinearities that dominate near the bifurcation. For example, the normal form of the Hopf bifurcation induces only the cubic distortion products $2f_1 - f_2$ and $2f_2 - f_1$ in response to stimulation at f_1 and f_2 . However, as described above, detection of signals across a certain frequency range requires an array of active microphones with distinct resonances. Presentation of f_1 and f_2 to such an array results in a cascade of combination tones at frequencies $f_1 \pm n(f_2 - f_1)$, $n \in \mathbb{N}$, for the distortion products at $2f_1 - f_2$ and $2f_2 - f_1$ are emitted by microphones tuned to these frequencies and interact with the stimuli at frequencies f_1 and f_2 as well as themselves to create other distortion products such as $3f_1 - f_2$, $3f_2 - f_1$, and so on. Such cascades of distortion

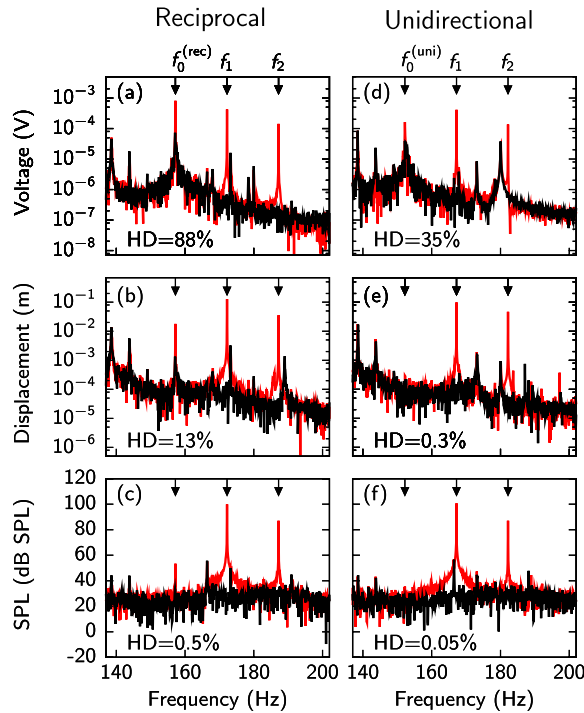

FIG. 3 (color online). Distortion products. We report the Fourier spectrum of the coil's voltage (a),(d), of the diaphragm's displacement (b),(e), and of the sound-pressure level detected by an external microphone (c),(f) for the reciprocal and the unidirectional active microphone. The system's response to stimulation at two frequencies f_1 and f_2 with $f_0 = 2f_1 - f_2$ is shown in red or grey, and the background signal without stimulation in black. The amount of distortion can be quantified through the harmonic distortion (HD, supplemental material [12]).

products have been recorded from the high-frequency region of the mammalian inner ear, where amplification is reciprocal [19].

Unidirectional coupling prevents the cascade of distortion products. Although distortion products such as $2f_1 - f_2$ and $2f_2 - f_1$ are formed in the coil, they are not emitted and hence cannot create further distortion products. The resulting reduction in the number of distortion products represents a significant advantage of the unidirectional active microphone over its reciprocal counterpart. Theoretical considerations indicate that the mammalian ear may employ the same strategy for detection of frequencies below about 2 kHz [9], which are employed predominantly in human speech [20] and music [21].

In summary, we have described a scheme for unidirectional mechanical amplification as well as its implementation in an active microphone that is ultrasensitive and nondistorting. This technology has potential applications in contexts that require the sensitive detection of mechanical signals at specific frequencies, for example, sonar, sonography, and perhaps the detection of seismic or even gravitational waves.

-
- [1] R. J. Potton, *Rep. Prog. Phys.* **67**, 717 (2004).
 - [2] J. R. Barber, *Elasticity (Solid Mechanics and Its Applications)* (Springer, New York, 2004), 3rd ed.
 - [3] B. I. Bleaney and B. Bleaney, *Electricity and Magnetism* (Oxford University Press, Oxford, 1976), 3rd ed.
 - [4] D. M. Pozar, *Microwave Engineering* (Wiley, New York, 2005), 3rd ed.
 - [5] N. J. McCullen, T. Mullin, and M. Golubitsky, *Phys. Rev. Lett.* **98**, 254101 (2007).
 - [6] L. Robles and M. A. Ruggero, *Physiol. Rev.* **81**, 1305 (2001).
 - [7] A. J. Hudspeth, *Neuron* **59**, 530 (2008).
 - [8] J. Ashmore, *Physiol. Rev.* **88**, 173 (2008).
 - [9] T. Reichenbach and A. J. Hudspeth, *Proc. Natl. Acad. Sci. U.S.A.* **107**, 4973 (2010).
 - [10] T. Reichenbach and A. J. Hudspeth, *Phys. Rev. Lett.* **105**, 118102 (2010).
 - [11] J. M. Eagle, *Loudspeaker Handbook* (Chapman & Hall, New York, 1997), 1st ed.
 - [12] See supplemental material at <http://link.aps.org/supplemental/10.1103/PhysRevLett.106.158701>.
 - [13] S. H. Strogatz, *Nonlinear Dynamics and Chaos* (Westview, Nashville, 1994).
 - [14] S. Wiggins, *Introduction to Applied Nonlinear Dynamical Systems and Chaos* (Springer, New York, 1990), 1st ed.
 - [15] V. M. Eguíluz *et al.*, *Phys. Rev. Lett.* **84**, 5232 (2000).
 - [16] S. Camalet *et al.*, *Proc. Natl. Acad. Sci. U.S.A.* **97**, 3183 (2000).
 - [17] A. Kern and R. Stoop, *Phys. Rev. Lett.* **91**, 128101 (2003).
 - [18] F. Jülicher, D. Andor, and T. Duke, *Proc. Natl. Acad. Sci. U.S.A.* **98**, 9080 (2001).
 - [19] L. Robles, M. A. Ruggero, and N. C. Rich, *J. Neurophysiol.* **77**, 2385 (1997).
 - [20] R. J. Baken and R. F. Orlikoff, *Clinical Measurement of Speech and Voice* (Singular Publishing Group, San Diego, 2000), 2nd ed.
 - [21] H. F. Olson, *Music, Physics, and Engineering* (Dover, New York, 1967), 1st ed.

Unidirectional mechanical amplification as a design principle for an active microphone

Tobias Reichenbach and A. J. Hudspeth

Supplementary EPAPS Document

Construction details

We modified a 6.5-inch-diameter speaker (Soundstream) by detaching the diaphragm from the voice coil and inserting between them a piezoelectric element 10 mm in length and capable of a displacement of $9.1 \mu\text{m}$ at a maximal voltage of 150 V (Thorlabs). The speaker's spider was modified to yield a smaller coil displacement X_c per volt in the range of the piezoelectric element. We connected the system to an electrical circuit that provided electrical feedback to the voice coil and hence mechanical amplification (Fig. 4). A variable resistance controlled the gain of this circuit and allowed adjustment to a Hopf bifurcation (Fig. 5). Another part of the circuit was designed to allow adjustment of the piezoelectric element's voltage to different magnitudes and phases (Fig. 4). Because the voltage in the electrical circuit operated at ± 15 V, we sent the signal into an amplifier with a fixed gain of $10\times$ and with a maximal output voltage of 150 V; its output was connected to the piezoelectric element. To counteract high-frequency noise in the circuit we added four two-pole low-pass filters (Fig. 4). To adjust unidirectionality (Fig. 6) we drove the voice coil with two additional piezoelectrical elements that were anchored in the speaker's wall and attached to the coil. Sounds were generated with Mathematica (Wolfram Research) and presented through a 4-inch-diameter speaker (Boss Audio Systems). For distortion products two frequencies f_1 and f_2 were generated independently and presented through two distinct speakers. The harmonic distortion (HD) of the signal was calculated as

$$\text{HD} = \sqrt{\frac{V_{2f_1-f_2}^2}{V_{2f_1-f_2}^2 + V_{f_1}^2 + V_{f_2}^2}} \quad (10)$$

in which V_f denotes the voltage at frequency f .

Nonlinearities

This section concerns the nonlinear behavior of the active microphones. We focus our discussion on the reciprocal active microphone; the unidirectional case follows similarly.

A system operating near a Hopf bifurcation can be described by the normal form [15]

$$\partial_t z = (a + i\omega_0)z + (b + ic)|z|^2 z + o(z^3). \quad (11)$$

Here z is a complex variable that, in the case of the active microphone, can encode the coil's displacement X and velocity $\partial_t X$. The resonant frequency is given by ω_0 and a, b, c are real coefficients with $a = 0$ representing the Hopf bifurcation. The linear part of Equation (11) can be derived from Equations (1-

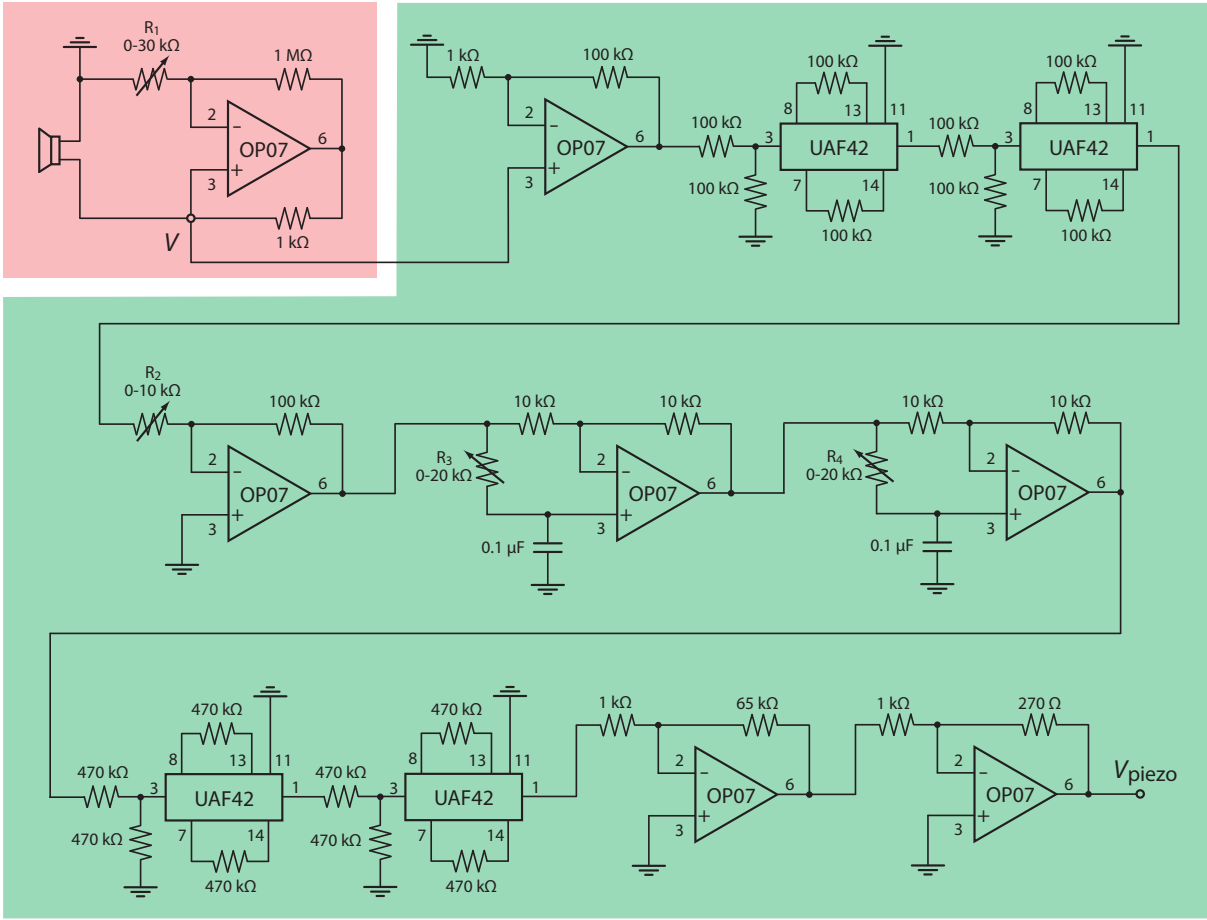

FIG. 4: Electrical circuit. The electrical circuit indicated in red provides positive feedback for mechanical amplification in the microphone and constitutes the circuit indicated in red in Fig. 1(d),(e). Its feedback gain can be adjusted by varying the resistance R_1 . The circuitry indicated in green converts the coil voltage V into a voltage V_{piezo} that is fed into an amplifier of maximal voltage 150 V and gain $10\times$ to yield the piezo voltage V_p . The gain of this circuit can be controlled through the variable resistance R_2 and its phase through the variable resistances R_3 and R_4 . Four two-pole low-pass filters are constructed with the help of filters (UAF42; Texas Instruments). This arrangement constitutes the circuit indicated in green in Fig. 1(e).

3). The nonlinear part results from nonlinear forces in the system. Although those forces may have different quadratic and cubic (as well as higher-order) contributions in the variables X and $\partial_t X$, a nonlinear transformation to the z -variable exists such that z agrees with $X, \partial_t X$ to linear order, such that the quadratic nonlinearities disappear, and such that the cubic nonlinearities take the form $|z|^2 z$ [Equation (11)]. Higher-order nonlinearities can be cast into the $U(1)$ -symmetric forms $|z|^4 z$, $|z|^6 z$, and so on.

When the normal form is periodically forced by $\tilde{f}e^{i\omega_0 t}$ at the resonant frequency and at the Hopf bifurcation ($a = 0$), and when the resulting displacement is small such that nonlinearities higher than the cubic can be ignored, the Fourier component \tilde{z} at ω_0 obeys

$$0 = (b + ic)|\tilde{z}|^2 \tilde{z} + \tilde{f} \quad (12)$$

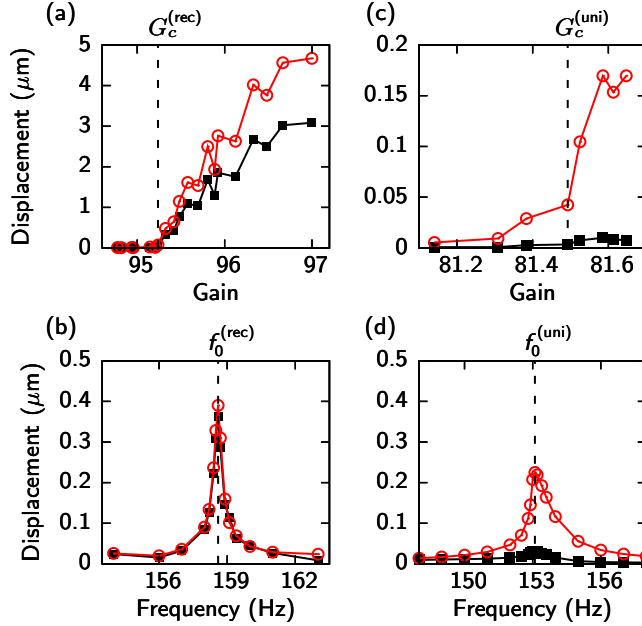

FIG. 5: Hopf bifurcation. We show the displacement of the coil (red circles) and of the diaphragm (black squares) for the reciprocal active (a,b) and the unidirectional active microphone (c,d). (a),(c), The reciprocal active and the unidirectional active microphone exhibit supercritical Hopf bifurcations at the critical values $G_c^{(\text{rec})} \approx 95.2$ and $G_c^{(\text{uni})} \approx 81.5$ of the gain in amplifier A . In the absence of an external stimulus, and apart from noise, the system is quiescent below G_c . For gains exceeding G_c spontaneous limit-cycle oscillations emerge in the coil. The diaphragm displacement reflects the Hopf bifurcation in the reciprocal but not in the unidirectional system. (b),(d), When operating at the Hopf bifurcation and stimulated by sound of different frequencies at a constant sound-pressure level of 60 dB SPL, the responses of the reciprocal and the unidirectional active microphones are tuned sharply around their resonant frequencies of $f_0^{(\text{rec})} \approx 158.6$ Hz and $f_0^{(\text{uni})} \approx 153.1$ Hz. The diaphragm's motion approximately equals the coil's motion in the reciprocal microphone, but is much smaller than the coil's displacement in the unidirectional system.

and thus exhibits a nonlinear response

$$|\tilde{z}| \sim |\tilde{f}|^{1/3} \quad (13)$$

with a power-law exponent of 1/3.

Our recordings show an exponent of about 1/2 (Fig. 3b,d) instead of the exponent 1/3 that characterizes the response close to the Hopf bifurcation. How can this exponent be understood through the speaker's nonlinear behavior? One nonlinear force in a speaker comes from the magnetic field generated by the moving voice coil that attracts the iron in the pole piece surrounding it [11]. At the coil's resting position, $X = 0$, this force is directed perpendicular to the coil's motion and balanced because of an approximately symmetric geometry. For displacements $X \neq 0$, however, a component F_{mag} of this force emerges which acts to restore the coil to its resting position; for small X the relative strength of this component to the net force is proportional to the coil's displacement X . The strength of the net force depends on the product of the magnetic field H generated by the coil and the pole piece's resulting magnetization $M(H)$.

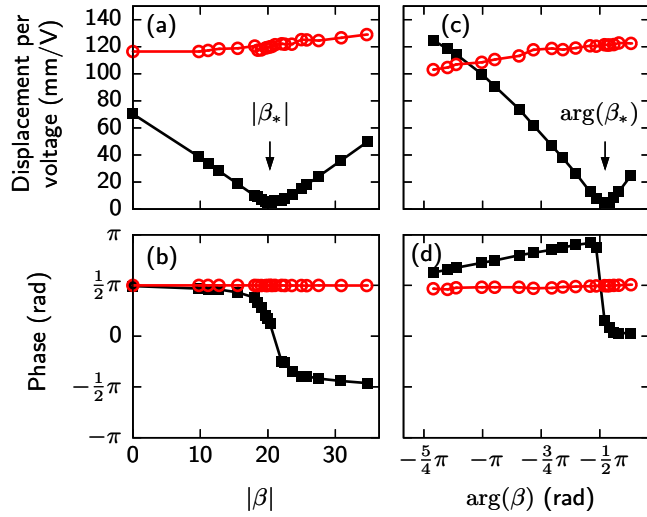

FIG. 6: Adjusting unidirectionality. Unidirectionality emerges when the ratio β of the piezoelectric-element voltage to the coil voltage, $\beta \equiv \tilde{V}_p/\tilde{V}$, which relates linearly to the coefficient α , is tuned to the critical value β_* of the correct amplitude and phase. We show the diaphragm displacement per coil voltage, \tilde{X}_d/\tilde{V} (black squares) as well as the coil displacement per coil voltage, \tilde{X}_c/\tilde{V} (red circles) that result when the coil but not the diaphragm is stimulated. (a),(b), The amplitude and phase of the displacement per voltage when the magnitude of β is varied and its phase is held constant at the critical value $|\beta_*|$. (c),(d), The amplitude and phase of the displacement per voltage when the phase of β is varied and its magnitude held constant at the critical value $|\beta_*|$. The coil's displacement per voltage is largely independent of β (a,b,c,d). However, the diaphragm's displacement almost vanishes at β_* , showing that the forces on the coil are not transmitted to the diaphragm and thus demonstrating unidirectionality (a,c). The diaphragm's displacement does not vanish completely at β_* because of nonlinearities in the piezoelectric element and because of noise. In agreement with theoretical analysis, the diaphragm's displacement undergoes a phase change of π around β_* (b,d).

Together we arrive at

$$F_{\text{mag}} \sim XHM(H). \quad (14)$$

The magnetic field H is proportional to the coil's velocity and thus, for sinusoidal motion, to the phase-shifted displacement X .

The dependence of the magnetization M on the magnetic field H is more complicated. For small magnetic fields the two are proportional: $M \sim H$. Small displacements X induce a small magnetic field H and therefore a cubic nonlinear force: $F_{\text{mag.}} \sim X^3$. Larger magnetic fields, however, lead to saturation at a maximal magnetization M_{max} and therefore a magnetization of $-M_{\text{max}}$ if the magnetic field is reversed. For these larger field strengths the magnetization may be approximated by a step function:

$$M(H) \approx \begin{cases} -M_{\text{max}} & \text{for } H < 0 \\ M_{\text{max}} & \text{for } H > 0 \end{cases}. \quad (15)$$

For larger displacements X the nonlinear force therefore assumes the approximate form

$$F_{\text{mag}} \sim |X|X. \quad (16)$$

This nonlinear force accordingly makes a contribution of $|z|z$ in Equation (11):

$$\partial_t z = (a + i\omega_0)z + (d + ie)|z|z + o(z^2) \quad (17)$$

with real coefficients d, e . In agreement with our observation, the term $|z|z$ induces a response $|\tilde{z}| = |\tilde{f}|^{1/2}$ at the bifurcation and at the resonant frequency. We hence argue that the exponent $1/2$ emerges in our active microphones because we operate at relatively high sound-pressure levels that induce saturation of the induced magnetic field in the pole piece and thus elicit a combination of higher-order nonlinearities summing to a contribution of $|z|z$ that dominates the cubic nonlinearity. If we could detect signals at the much lower sound-pressure levels at which noise dominates in our system, we would expect to find a regime in which the magnetization operates in the unsaturated regime and a cubic nonlinearity emerges. We note that other nonlinearities, such as that in the spider's stiffness [11], contribute as well. We expect, however, that they contribute to cubic nonlinear behavior. We have observed a cubic nonlinear response in a smaller speaker (4-inch-diameter, Boss Audio Systems) for which the nonlinear contribution F_{mag} described above is apparently not dominant.